

Slide Sledge[®] Excavator 20 Ton Class Application Chart

MULTI-HEAD HAMMER

Operating Weight: 40,000 - 49,000 lb.

MACHINE MODELS

CASE CX210, CX225SR
CAT 318C, 320C "B", 322C "B"
DAEWOO SOLAR 220 LC-V
DEERE 200C LC, 225C RTS
HITACHI ZX200 LC, ZX225US
HYUNDAI R210LC-3
JCB JS220
KOBELCO SK210LC, 200SRLC, 235SRLC
KOMATSU PC200LC-7, PC228USLC-3
LINK-BELT 210LX, 225 SPIN ACE
NEW HOLLAND EC215-LC, EW200
VOLVO EC210B

SAFETY FIRST

1. Wear Safety Equipment.
2. Keep hands and feet clear.
3. Beware of flying objects.

Prior to removing any pins or parts refer to Manufacturers Service manual for proper procedures for securing and stabilizing equipment.

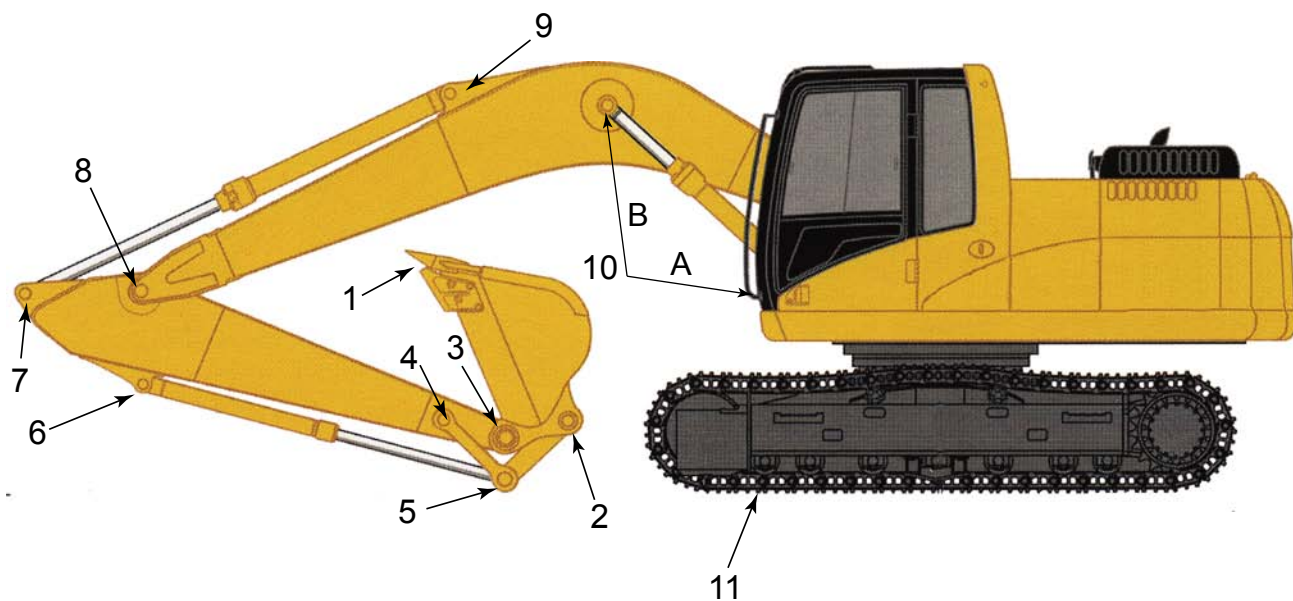

Item	Description
1	Bucket Teeth
2	Bucket to Linkage Pin
3	Bucket to Stick Pin
4	Stick Linkage Pin
5	Bucket Cylinder Rod End to Linkage
6	Bucket Cylinder Pin
7	Stick Cylinder Rod End Pin
8	Stick to Boom Pin
9	Cylinder Pin to Stick
10	A. Boom to Frame (insert ONLY) B. Boom Cylinder Rod End
11	Track Master Pin (Slip Pin)

See back for Pin Removal / Insertion specifications and recommended Slide Sledge[®] tool kit.

The following removal and insertion tips are manufacturer recommendations for this model. Other model excavators may use similar tips and tools for similar removals. Consult with manufacturer for specific models and uses.

Item	Tool/Tip	Description	Part#
#1	R/I Tool	14 lb./30" Slide Sledge	211301
	R/I Tip	1/2" Bucket Tooth Remover	213304
	R/I Tip	1/2" Bucket Tooth Inserter	213303
#2	R/I Tool	13 lb./46" Slide Sledge	211203
	R/I Tip	1 1/4" Pin Driver	213103
#3	R/I Tool	13 lb./46" Slide Sledge	211203
	R/I Tip	1 1/4" Pin Driver	213103
#4	R/I Tool	13 lb./46" Slide Sledge	211203
	R/I Tip	1 1/4" Pin Driver	213103
#5	R/I Tool	13 lb./46" Slide Sledge	211203
	R/I Tip	1 1/4" Pin Driver	213103
#6	R/I Tool	13 lb./46" Slide Sledge	211203
	R/I Tip	1 1/4" Pin Driver	213103
#7	R/I Tool	13 lb./46" Slide Sledge	211203
	R/I Tip	1 1/4" Pin Driver	213103
#8	R/I Tool	13 lb./46" Slide Sledge	211203
	R/I Tip	1 1/4" Pin Driver	213103
#13	R/I Tool	13 lb./46" Slide Sledge	211203
	R/I Tip	1 1/4" Pin Driver	213103
#10	R/I Tool	13 lb./46" Slide Sledge	211203
	A	Insert Tip	2" Pin Driver
B	R/I Tip	1 1/4" Pin Driver	213103
#11	R/I Tool	13 lb./46" Slide Sledge	211203
	R/I Tip	7/8" Pin Driver	213102
	Accessory	5 lb. Handle Weight	211808

Recommended Tool Kit for 20 Ton Class Excavators

Product	Part#
13 lb./46" Slide Sledge	211203
14 lb./30" Slide Sledge	211301
7/8" Pin Driver	213102
1 1/4" Pin Driver	213103
2" Pin Driver	213104
1/2" Bucket Tooth Remover	213304
1/2" Bucket Tooth Inserter	213303
Utility Wedge Tip	213528
5 lb. Handle Weight	211808

Removal and installation should only be performed on pins that have been properly serviced and maintained.