

MACHINE MODELS

CASE 621D, 621D XR, 621D XT
CAT 930G
DAEWOO MEGA 250-V
DEERE 624H, 624J, TC62H
HYUNDIA HL740-7, HL740XTD-7
JCB 436 HT, 436 ZX
KAWASAKI 70ZV
KOMATSU WA250-5, WA250PT-5, WA320-3
NEW HOLLAND LW170-TC, LW170.B
TEREX TXL250-1
VOLVO L70E, L90D, L90E

SAFETY FIRST

1. Wear Safety Equipment.
2. Keep hands and feet clear.
3. Beware of flying objects.

Prior to removing any pins or parts refer to Manufacturers Service manual for proper procedures for securing and stabilizing equipment.

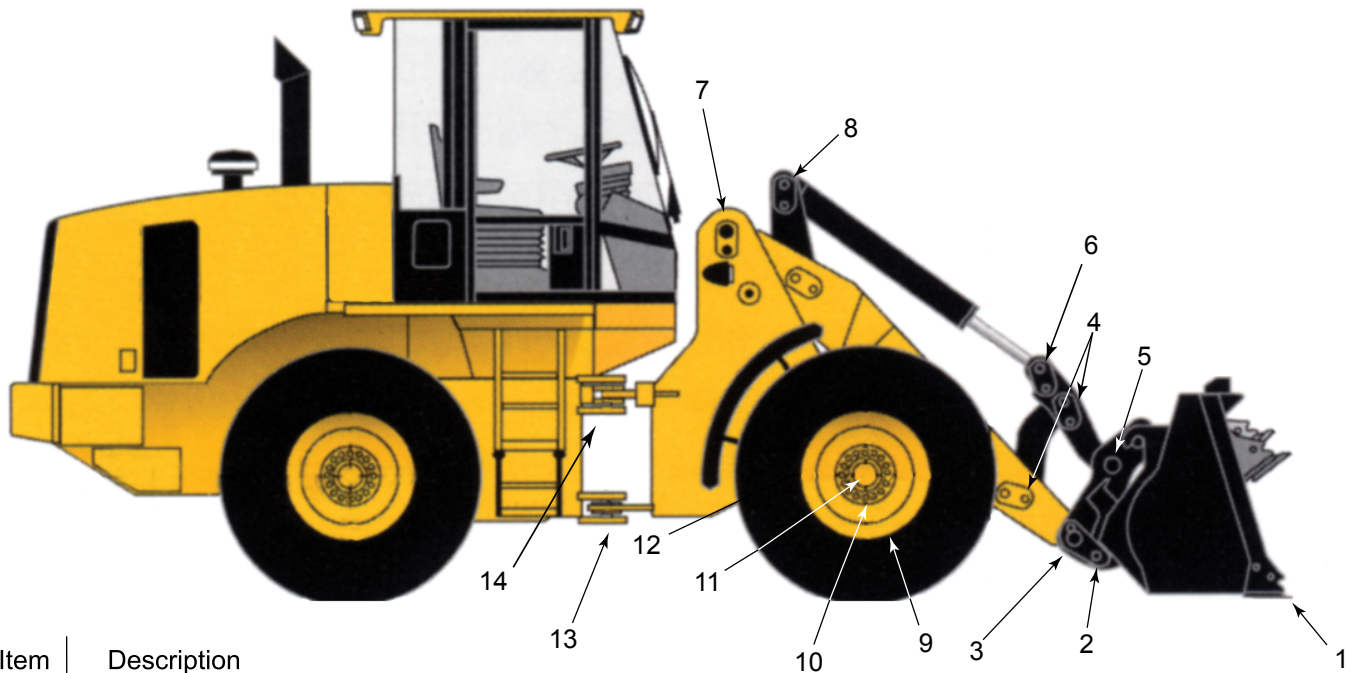

Item	Description
1	Bucket Teeth / Tips
2	Bucket Pin
3	Quick Coupler Pin
4	Upper Bell Crank Pin
5	Bell Crank Pin
6	Tilt Cylinder Rod End
7	Loader Frame to Main Frame Pin
8	Tilt Cylinder Pin
9	Tire Bead
10	Wheel Stud Remover
11	Race Wheel Bearings
12	Steering Cylinder to Frame Assembly
13	Articulation Pin
14	Steering Pin to Frame

See back for Pin Removal / Insertion specifications and recommended Slide Sledge® tool kit.

The following removal and insertion tips are manufacturer recommendations for this model. Other model wheel loaders may use similar tips and tools for similar removals. Consult with manufacturer for specific models and uses.

	Tool/Tip	Description	Part#
#1	R/I Tool	14 lb./30" Slide Sledge	28050
	R/I Tip	1/2" Ripper Tooth Pin Remover	25280
#2	R/I Tip	1/2" Ripper Tooth Pin Inserter	25270
	R/I Tool	13lb./46" Slide Sledge	26050
#3	R/I Tip	1 1/4" Pin Driver	25290
	R/I Tool	13lb./46" Slide Sledge	26050
#4	R/I Tip	2" Pin Driver	25291
	R/I Tool	13lb./46" Slide Sledge	26050
#5	R/I Tip	2" Pin Driver	25291
	R/I Tool	13lb./46" Slide Sledge	26050
#6	R/I Tip	2" Pin Driver	25291
	R/I Tool	13lb./46" Slide Sledge	26050
#7	R/I Tip	2" Pin Driver	25291
	R/I Tool	13lb./46" Slide Sledge	26050
#8	R/I Tip	2" Pin Driver	25291
	R/I Tool	13lb./46" Slide Sledge	26050
#9	R/I Tip	2" Pin Driver	25291
	R/I Tool	21lb./46" Slide Sledge	29050
#10	R/I Tip	Small Tire Bead Breaker	25350
	Accessory	5 lb. Handle Weight	1001001
#11	R/I Tip	2" Pin Driver	25291
	R/I Tool	14 lb./30" Slide Sledge	28050
#12	R/I Tip	2" Pin Driver	25291
	R/I Tool	9lb./30" Slide Sledge	25050
#13	R/I Tip	Large Plate Driver	25320
	R/I Tool	14 lb./30" Slide Sledge	28050
#14	R/I Tip	1 1/4" Pin Driver	25290
	R/I Tool	14 lb./30" Slide Sledge	28050
	R/I Tip	1 1/4" Pin Driver	25290

Recommended Tool Kit for Small Wheel Loaders

Product	Part#
9lb./30" Slide Sledge	25050
13 lb./46" Slide Sledge	26050
14lb./30" Slide Sledge	28050
21lb./46" Slide Sledge	29050
1 1/4" Pin Driver	25290
2" Pin Driver	25291
1/2" Bucket Tooth Remover	25280
1/2" Bucket Tooth Inserter	25270
Small Tire Bead Breaker	25350
Large Plate Driver	25320
5 lb. Handle Weight	1001001

Removal and installation should only be performed on pins that have been properly serviced and maintained.